

FINALLY... A FAST HAND DRYER.



FAST! Dries Hands *Completely* in 10-15 Seconds

Excel's research team has developed the **XLERATOR®** with **patented technology** that delivers **three-times-faster** hand drying performance. Conventional hand dryers take from 30 to 45 seconds to get a user's hands totally dry, and very few of us are willing to wait that long. With the automatic sensor-activated **XLERATOR**, not only do your hands get dry in 10 to 15 seconds, but consumer test participants report that their hands also felt *warm, soft and really dry.*



Uses 80% Less Energy.

Not only does the **XLERATOR** dry hands in one third of the time required by conventional hand dryers, our hand-drying system is designed to run on 15-amp service (making it great for older buildings). The combination of these two factors results in 80% less energy cost per use vs. conventional hand dryers.

3 Times Faster!

GreenSpec® Approved and Qualifies for LEED® Credits.



XLERATOR is the first hand dryer to be GreenSpec Listed because it meets a number of GreenSpec standards; conserves energy, has low maintenance requirements and reduces waste.



XLERATOR helps your facility qualify for several different LEED (Leadership in Energy and Environmental Design) Credits in the new 2009 Rating Systems including EA Credit 1 - Optimize Energy Performance, now a mandatory credit for any LEED-certified facility.

XLERATOR also *lowers a facility's Carbon Footprint.* Ask to see our Life Cycle Assessment (LCA) Study Results.

95% Cost Savings vs. Paper Towels

Converting to the **XLERATOR** hand dryer will result in more than a 95% savings vs. paper towel costs. In addition to paper towels, the following costs are also eliminated: ordering, storing, replenishing, collecting and disposing of bacteria-laden paper towel waste. This results in a **Payback of Less Than One Year!**

Setting a New Standard

After a decade in the marketplace, the **XLERATOR** hand dryer has received numerous awards and designations, appeared in case study articles done by prestigious trade publications, and been featured on national television programs! Because of its proven performance and customer satisfaction, **XLERATOR** is being specified in many high-profile facilities and has become... **THE NEW INDUSTRY STANDARD!**



XLERATOR® IS RECEIVING A LOT OF ATTENTION

Ask about our Promotional Video
As seen on CNN Headline News
hosted by Terry Bradshaw.



(Available on CD. Or view this and other videos on our web site.)

TELEVISION APPEARANCES



AWARDS

Best New Product - Technology
(International Hotel, Motel and Restaurant Show)

Top Ten Green Product
(Environmental Building News)

Award for Design Excellence (ADEX)
(Design Journal ADEX Platinum Award)

Citation of Excellence
(Buildings Product Innovations Awards)

FEATURED ARTICLES

The Wall Street Journal

Architectural Record

American School and University

Environmental Design and Construction

AVAILABLE FROM

SSS® TRIPLE S
NATIONWIDE
SANITARY SOLUTIONS

1-800-323-2251

www.triple-s.com



Contract Holder
#GS-07F-0017T

Excel Dryer has been awarded a contract by the GSA (General Services Administration) which offers special pricing to all Federal Government Agencies.

XLERATOR® HAND DRYER SPECIFICATIONS



Model XL-BW
Surface-mounted, Automatic,
White Polymer (BMC) Cover



Model XL-W
Surface-mounted, Automatic,
White Epoxy Painted Cover



Model XL-GR
Surface-mounted, Automatic,
Graphite Textured Painted Cover



Model XL-C
Surface-mounted, Automatic,
Chrome Plated Cover



Model XL-SB
Surface-mounted, Automatic,
Brushed Stainless Steel Cover



Model XL-SI*
Surface-mounted, Automatic,
Custom Special Image Cover

*Note: Exclusive digital image technology allows for the addition of Company, School or Team logos with any color, design or a 'green message'

Suggested Mounting Heights
From floor to Bottom of Dryer

	Hand Dryers
Mens'	45" (114 cm)
Ladies'	43" (109 cm)
Teenagers'	41" (104 cm)
Sm. Children	35" (89 cm)
Handicapped	37" (94 cm)

Units are 1500 Watts
and available as Specified in:

110/120V	12.5 Amp	60 Hz
208V	7.0 Amp	60 Hz
220/240V	6.5 Amp	60 Hz
277V	5.5 Amp	60 Hz
220/240V	6.5 Amp	50 Hz

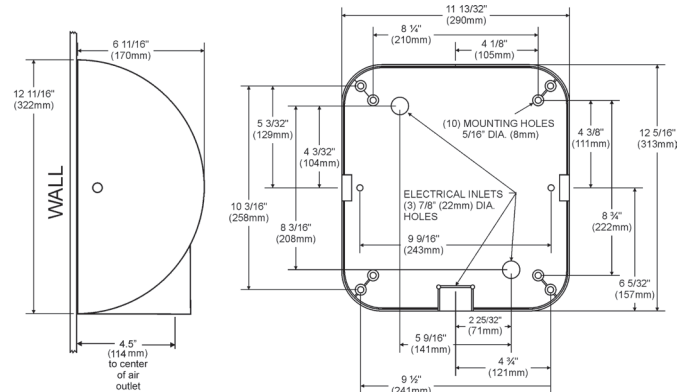

Dimensions: 11 3/4" lg. X 12 11/16" high x 6 11/16" deep
(298 mm lg. X 322 mm high x 170 mm deep)

Weight: XL-BW - 15 lbs. (6.80 kgs.) XL-SB 16 lbs. (7.26 kgs.)
XL-W, XL-GR, XL-C, XL-SI - 17 lbs. (7.71 kgs.)

MECHANISM

- Motor shall be a thermally protected, series commutated, through-flow discharge vacuum motor/blower (5/8 hp / 20,000 rpm) which provides air velocity of up to 19,000 lfm (linear feet per minute) at the air outlet and 16,000 lfm at the hands (4 inches [102 mm] below air outlet).
- Heating element (970 w) is constructed of Nichrome wire and mounted inside the blower housing, thereby being vandal proof. It shall be protected by an automatic resetting thermostat, which shall open whenever air flow is cut off and shall close when flow of air is resumed. It shall produce an air temperature of up to 135°F (57°C) at a 72°F (22°C) ambient room temperature at the hands (4 inches [102 mm] below air outlet).
- Control assembly is activated by an infrared optical sensor located next to the air outlet. The dryer shall operate as long as hands are under the air outlet. There is a 35-second lockout feature if hands are not removed.

LIMITED WARRANTY

The dryer shall be guaranteed to be free from defects for a period of five (5) years. Warranty shall include labor performed at factory as well as the repair or exchange of defective parts, at manufacturer's option.

QUANTITY RECOMMENDATIONS

One dryer for every two washbasins is sufficient for most applications. If restroom traffic is unusually heavy, we suggest one dryer per washbasin in small installations and two dryers for every three washbasins in larger installations. When a 54" washfountain is used, we suggest four to five dryers.

AVAILABLE FROM

SSS® TRIPLE S
NATIONWIDE
SANITARY SOLUTIONS
1 - 8 0 0 - 3 2 3 - 2 2 5 1
www.triple-s.com

Recess Kit - Meets ADA Protrusion Requirement of 4 inches (102 mm)



RECESS KIT (Optional)

Dimensions: 16 3/8" wide x 26" high x 3 3/8" deep
(416 mm wide x 660 mm high x 86 mm deep)
Weight: 11 lbs. (4.99 kgs.)

Note: Bottom of recessed wall box should be 10" (254 mm) below suggested mounting height for dryer (see chart).

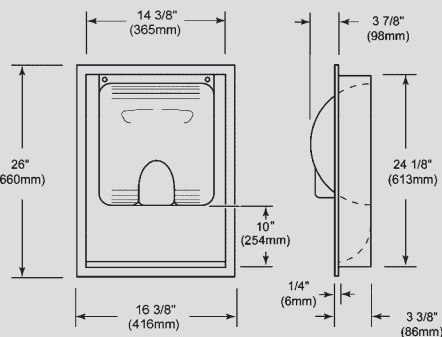

XLERATOR® HAND DRYER CONSTRUCTION

- Cover shall be one of the following: **Die-cast zinc alloy** - One-piece, heavy-duty, rib-reinforced, lightweight, unbreakable, rustproof and all exposed surfaces shall be bright chrome plated or finished with chip-proof, electrostatically applied epoxy paint. **Bulk Molding Compound (BMC)** - White reinforced thermoset polymer. **Stainless Steel** - with a brushed finish. **Special Image** - Digital image applied to cover using patented Kolorfusion Sublimation Decoration process. All covers will be fastened to a wall plate by two chrome plated tamper-proof bolts.
- Wall plate shall be equipped with (3) 7/8" (22 mm) diameter holes, one of which shall be suitable for use with surface conduit, for ease of wiring.
- All internal parts shall be coated according to Underwriters' Laboratories, Inc. requirements.
- Entire mechanism shall be internally grounded.
- Optional recess kit includes a wall box (22 ga) and dryer mounting plate (16 ga) made from 18-8 Type 304 brushed stainless steel. A stainless steel tether is connected to the dryer mounting plate to hold the dryer in position when servicing.



See us in Sweet's
CD Online Catalog Files



Printed on recycled paper
Printed in the U.S.A.