



# CANISTER VACUUM

## MODEL SC-19

### INTRODUCTION

### OPERATING & MAINTENANCE INSTRUCTIONS

---

#### READ THIS BOOK

This operator's book has important information for the use and safe operation of this machine. Read this book carefully before starting the machine. Keep this book and tell all operators to read the book. If you do not follow the instructions, you can cause an injury or damage equipment, furniture or buildings.

For additional information refer to the Triple S website [www.triple-s.com](http://www.triple-s.com) or write to:

**Triple S**  
2 Executive Park Drive  
Billerica, MA 01862

Carefully inspect all components to ensure that there is no concealed freight damage. If such damage is discovered, file a "CONCEALED DAMAGE REPORT" immediately with the delivering carrier.

The contents of this manual are based on the latest product information available at the time of publication. Triple S reserves the right to make changes or improvements to its machines without notice.

#### FOR YOUR CONVENIENCE, RECORD THIS IMPORTANT INFORMATION:

MODEL \_\_\_\_\_

SERIAL NUMBER \_\_\_\_\_

PART NUMBER \_\_\_\_\_

DATE PURCHASED \_\_\_\_\_

# IMPORTANT SAFETY INSTRUCTIONS

## READ AND UNDERSTAND ALL WARNINGS AND INSTRUCTIONS BEFORE USING THIS APPLIANCE!

### WARNING! To reduce the risk of fire, electric shock, or injury:

1. Do not leave appliance when plugged in. Unplug from outlet when not in use and before servicing.
2. Do not use outdoors or on wet surfaces.
3. Do not allow to be used as a toy. Close attention is necessary when used by or near children.
4. Use only as described in this manual. Use only manufacturer's attachments.
5. Do not use with damaged cord or plug. If appliance should not work as it should, has been dropped or damaged, left outdoors, or dropped into water, return it to service center.
6. Do not pull or carry by cord, use cord as handle, close a door on cord or pull cord around sharp edges or corners. Do not run appliance over cord. Keep cord away from heated surfaces.
7. Do not unplug by pulling on cord. To unplug, grasp the plug, not the cord.
8. Do not handle plug or appliance with wet hands.
9. Do not put any objects into opening. Do not use with any opening blocked: keep free of dust, lint, hair and anything that may reduce airflow.
10. Keep hair, loose clothing, fingers and all parts of the body away from openings and moving parts.
11. Turn off all controls before unplugging.
12. Use extra care when cleaning on stairs.
13. Do not use to pick up flammable or combustible liquids such as gasoline or use in areas where they may be present.
14. Connect to a properly grounded outlet only.
15. Do not pick up anything that is burning or smoking, such as cigarettes, matches or hot ashes.
16. Do not use without dust bag and/or filters in place.
17. Do not use this vacuum for pick-up of wet debris; this vacuum is for dry pick-up only.

## Grounding Instructions

This machine must be grounded. If it should malfunction or break down, grounding provides a path of least resistance for electric current to reduce the risk of electric shock. This machine is equipped with a cord having an equipment-grounding conductor and grounding plug. The plug must be inserted into an appropriate outlet that is properly installed and grounded in accordance with all local codes and ordinances.

**WARNING** - Improper connection of the equipment-grounding conductor can result in a risk of electric shock. Check with a qualified electrician or service person if you are in doubt as to whether the outlet is properly grounded. Do not modify the plug provided with the machine - if it will not fit the outlet, have a proper outlet installed by a qualified electrician.

This machine is for use on a nominal 120-volt circuit, and has a grounded plug that looks like the plug illustrated in figure A. A temporary adapter that looks like the adapter illustrated in figures B and C may be used to connect this plug to a 2-pole receptacle as shown in figure B if a properly grounded outlet is not available. The temporary adapter should be used only until a properly grounded outlet (figure A) can be installed by a qualified electrician. The green colored rigid ear, lug, or the like extending from the adapter must be connected to a permanent ground such as a properly grounded outlet box cover. Whenever the adapter is used, it must be held in place by a metal screw.

*NOTE: In Canada, the use of a temporary adapter is not permitted by the Canadian Electrical Code*

### EXTENSION CORDS

Use only three-wire 16/3 or larger gauge approved extension cords that have three-prong grounding type plugs and three-pole receptacles that accept the appliance's plug. Replace or repair any damaged cords or plugs.

When servicing, refer to authorized person only. Use only identical replacement parts.

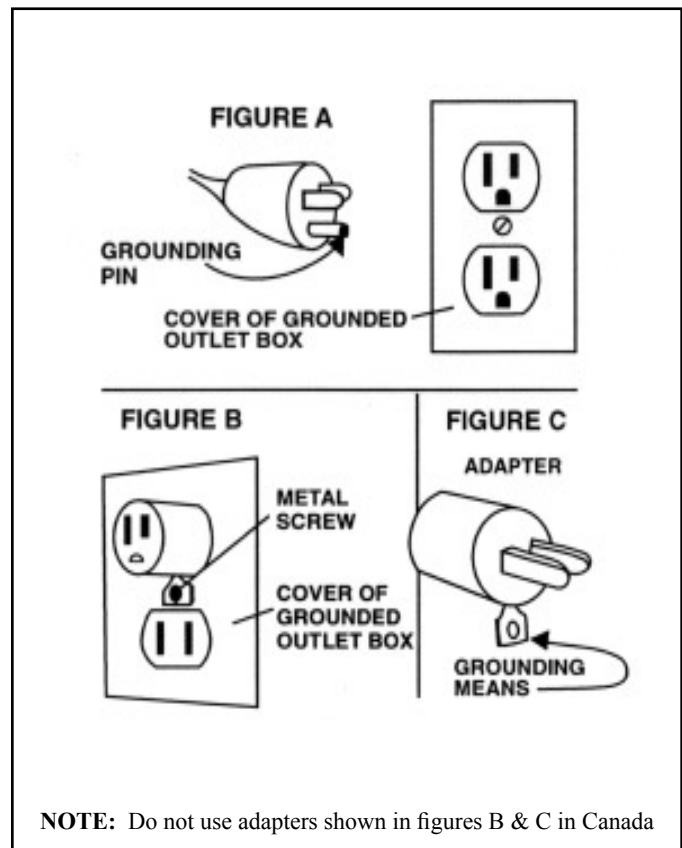

**NOTE:** Do not use adapters shown in figures B & C in Canada

# ASSEMBLY AND OPERATION

---

Unpack your vacuum from its carton and inspect the machine, hose assembly and tools for any damage. If there is damage to any component, file a claim with the carrier immediately.

## Assembly

---

This machine requires little assembly before operation. However, the following steps must be taken to ensure proper operation.

1. Install a **filter bag** into the tank. Release the hook located on each side of the machine's tank and motor assembly. Lift the cover off and set it aside. Slide the bag retaining plate (Item 6) off the bag adapter. Then push the filter bag opening over the adapter and slide the bag retaining plate over both the bag cuff and the adapter. Be sure the filter bag follows the perimeter of the tank; the center area must remain clear for replacement of the cover with motor assembly. Replace the cover and fasten both hooks.
2. Insert the **vacuum hose assembly** into the adapter. Line up the tabs on the vacuum hose with the notches on the adapter and twist to secure in place. Then attach the wand and selected tool. The wand and tools attach by simply pushing them together.

## Operation

---

The Model shown in this manual is intended for commercial use and is to be used for **only dry pick-up applications**.

1. Before use, be sure a **filter bag** has been properly installed in the machine (reference assembly instructions).
2. Attach the **hose assembly, wand and selected tools**.
3. Plug the **power cord** into a 115-volt, 60 cycle, grounded outlet.
4. Press the **power switch** to start the vacuum. The switch is located on the back left side of the vacuum, under the accessory holder.
5. The **vacuum suction** is adjustable by turning the red knob located on the back right side of the vacuum. Minor adjustments to the vacuum suction can also be made by sliding the lever on the bent wand section of the hose assembly. For maximum pick-up the opening must be closed, for reduced suction expose the opening.

## Tools

Four tools are provided with the vacuum: the combination floor tool, upholstery tool, crevice tool and dusting brush. Each is used by inserting them directly into the free end of the vacuum hose/wand.

An adjustable metal wand is also provided. Simply push on its knob to adjust the length.

## Servicing

---

**Warning: Always unplug your vacuum before performing any service. Severe personal injury could result if the electrical power is not disconnected.**

1. **Vacuum Filter Bag:** When full, remove the paper filter bag and install a new one.
2. **Power Cord:** Check the cord for cuts or nicks. If damaged, have the cord replaced at a factory authorized service center.
3. **Caster/Wheels:** Remove any string or debris that may restrict their free movement. Wipe the treads clean.
4. **Tools and Wand:** Inspect to ensure there is no obstruction of airflow. Remove any debris if found.
5. **Vacuum Filter:** A foam filter is provided with the vacuum. It is located in the cover assembly; turn the cover upside down and push the tabs toward the center of the cover to release the filter rest (Item 5) from the top cover (Item 2). The filter requires periodic cleaning or replacement. Remove any dust and debris by vacuuming with a different vacuum cleaner. Note: There is also an **optional HEPA filter** available for this vacuum. In order to obtain the optimal performance from a HEPA filter, it should be replaced when dirty.
6. **Inlet Motor Filter:** This vacuum has a filter to protect the motor assembly. It requires periodic cleaning or replacement. The filter is located inside the tank, over the vacuum motor. Remove any dust and debris by vacuuming with a different vacuum cleaner.
7. **Vacuum Motor Maintenance:** Have the vacuum motor inspected annually by a factory authorized service technician. If the carbon brushes are worn, they should be replaced. This service will prolong the life of the vacuum motor.

# SC-19 Canister Vacuum

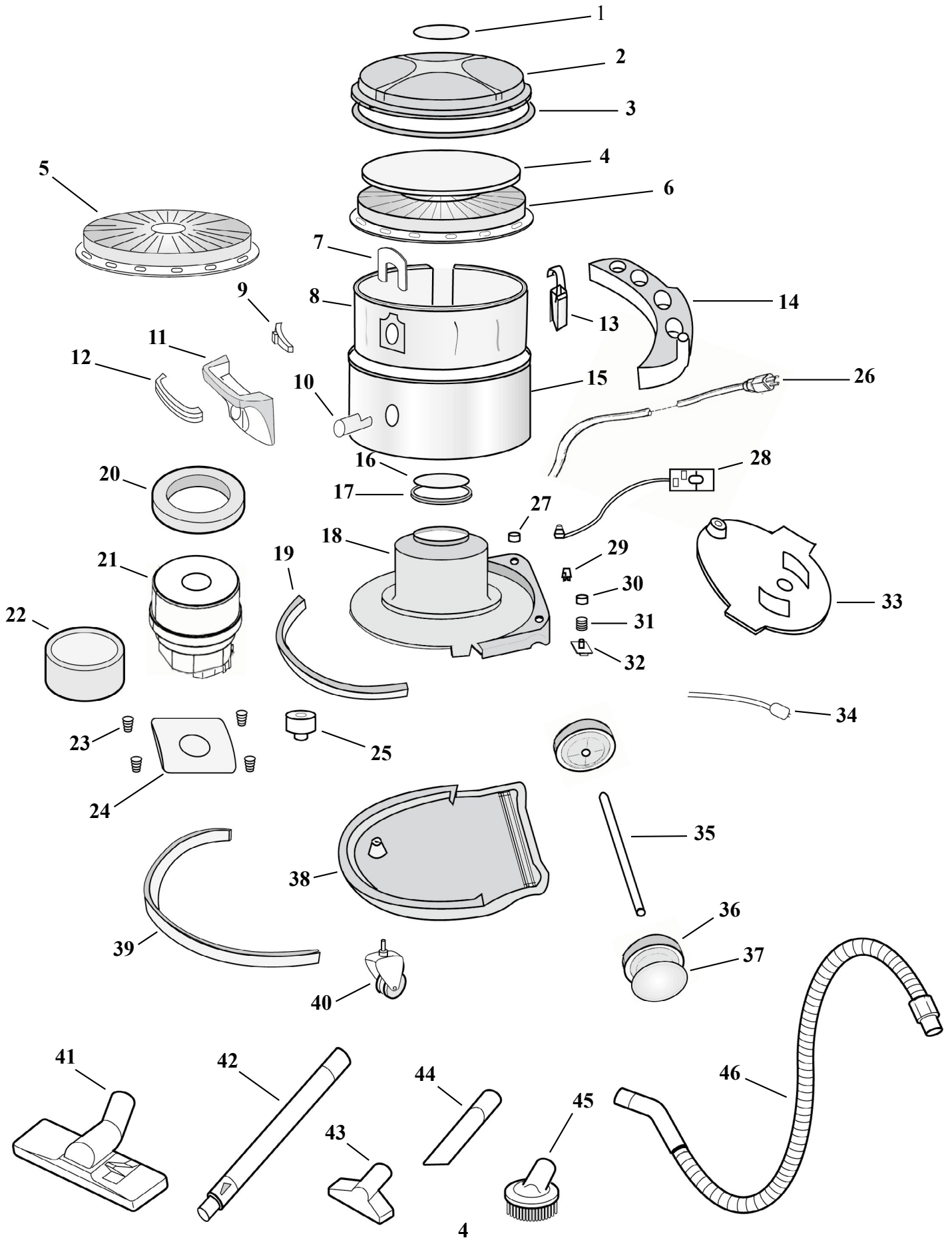

## SC-19 Parts List

ITEM	PART NUMBER	DESCRIPTION	QTY
1	612316	Decoration Cover	1
2	612317	Top Cover	1
3	613403	Gasket, Vac. Hd.	1
4	613301	Sponge Filter	1
5	613303	HEPA Filter - Optional	
6	617503	Filter Rest	1
7	616605	Bag Retaining Plate	1
8	610610	Paper Bags, pack of 10	
9	611305	Dustbag Block	1
10	619001	Vacuum Tube	1
11	613901	Carrying Handle	1
12	612315	Handle Cover	1
13	614501	Hook	2
14	616606	Accessory Plate	1
15	618601	Stainless Steel Tank	1
16	613302	Inlet Filter	1
17	613401	Gasket	1
18	612315	Motor Cover	1
19	618505	Sponge Bar	1
20	613402	Motor Gasket	1
21	605240	Motor	1
22	618502	Sound Deadening	1
23	618301	Support Spring for Motor	4
24	616605	Spring Plate	1
25	618503	Motor Support	1
26	908106	Power Cord	1
27	615005	Speed Control Knob	1
28	911282	PCB Vacuum Control	1
29	618506	Socket	1
30	615006	Knob - On/Off Switch	1
31	618302	Switch Spring	1
32	911283	On/Off Switch	1
33	618506	Motor Support	1
34	911284	Thermal Protector	1
35	617703	Wheel Shaft	1
36	619704	Wheel	2
37	611505	Cap - Wheel	2
38	611306	Base	1
39	611205	Bumper	1
40	619705	Caster	1
41	608813	Combination Floor Tool	1
42	639802	Metal Wand - Telescoping	1
43	618807	Upholstery Tool	1
44	608815	Crevice Tool	1
45	618806	Dusting Brush	1
46	614104	Hose Asm.	1

# NOTES

---

# NOTES

---

**SSS CANISTER VACUUM, MODEL SC-19  
LIMITED WARRANTY**

The SSS Canister Vacuum, Model SC-19 has been manufactured, tested and inspected in accordance with specific engineering requirements, and is WARRANTED by the manufacturer to be free from defects in workmanship and materials.

This warranty is, however, subject to the following qualifications, conditions and limitations which are set forth to provide you and all users of the SSS Canister Vacuum, Model SC-19 with information concerning the duration, extent, availability and applicability of this Limited Warranty, the procedure to be taken to obtain its performance and other information concerning the manufacturer's warranty policy.

**1. TO WHOM EXTENDED AND DURATION OF ITEMS COVERED**

This warranty extends to the original consumer purchaser from the date it was purchased and for the items and periods as follows:

One (1) year parts and labor – All components unless excluded below.

**2. PARTS NOT COVERED BY WARRANTY**

Certain parts of the SSS Canister Vacuum require replacement in the ordinary course of use due to normal wear by reason of their characteristics. This warranty does not cover the following normal wear items:

<u>Part Number</u>	<u>Part Name</u>
908106	Cord Assembly
614104	Vacuum Hose Assembly
613301	Sponge Filter
610610	Paper Bags
613302	Inlet Filter
613303	HEPA Filter
608813	Combination Floor Tool
618807	Upholstery Tool
608815	Crevice Tool
618806	Dusting Brush

**3. EXCEPTIONS AND EXCLUSIONS FROM WARRANTY**

The SSS Canister Vacuum is required to be used on electric current as indicated on the nameplate. Otherwise damage, defects, malfunctions or other failures of the SSS Canister Vacuum arising from use on electric current not as indicated are excepted and excluded from this warranty.

Defects, malfunctions, failure or damage of the SSS Canister Vacuum caused by improper, unreasonable or negligent use or abuse while in the possession of the consumer are likewise excluded from this warranty.

If repair is done on your SSS Canister Vacuum by anyone other than those below designated as authorized to perform such work without first having obtained factory instructions, the manufacturer, at its sole option, may determine that this warranty will not apply and that reimbursement for such repair will not be made because of the failure to comply with such factory specified instructions.

**4. PROCEDURE TO BE TAKEN TO OBTAIN PERFORMANCE OF WARRANTY**

To secure repair of the SSS Canister Vacuum or any warranted parts under this warranty, the following procedure should be taken: The inoperative SSS Canister Vacuum or warranted parts, together with satisfactory evidence of the purchase date, must be delivered with shipping and delivery charges prepaid to the Dealer from whom purchased.

If you are unable to locate the Dealer, you may write or otherwise communicate with **Triple S, 2 Executive Park Drive, Billerica, MA 01862** for instructions before repair service is performed by anyone else. In such event Triple S will provide either the location of a closely available Triple S Distributor Service Department or other factory instructions.

Upon compliance with the above procedure, all warranted defects will be repaired, at no additional charge or costs to the consumer, and the repaired product returned to the consumer, with all shipping and delivery charges prepaid.

In following the procedures above set forth PLEASE MAKE CERTAIN to state the Triple S model, type and serial number as shown on the name plate of the SSS Canister Vacuum.

**REPLACEMENT**

In the event of the defect, malfunction or failure of your SSS Canister Vacuum or any warranted part to conform with this warranty, the manufacturer may at its sole option and own expense, replace the SSS Canister Vacuum or any warranted part with another new identical or reasonably equivalent model or part in lieu of repairing the defect.

**5. NO REFUND OF PURCHASE PRICE**

Triple S will not, as a matter of its warranty policy, refund the consumer's purchase price.

**6. WARRANTY REGISTRATION CARD FOR YOUR SSS CANISTER VACUUM AND REQUESTS FOR INFORMATION**

Please fill out the warranty registration card accompanying your SSS Canister Vacuum, giving complete information as requested on the card, and return to Triple S.

This warranty is in lieu of all other expressed or implied warranties.

