



Scepter PE50 5 Gallon Box Extractor

INTRODUCTION

OPERATING & MAINTENANCE INSTRUCTIONS

READ THIS BOOK

This operator's book has important information for the use and safe operation of this machine. Read this book carefully before starting the machine. Keep this book and tell all operators to read the book. If you do not follow the instructions, you can cause an injury or damage equipment, furniture or buildings.

For new books write to:

Triple S
2 Executive Park Drive
Billerica, MA 01862

Carefully inspect all components to ensure that there is no concealed freight damage. If such damage is discovered, file a "CONCEALED DAMAGE REPORT" immediately with the delivering carrier.

The contents of this manual are based on the latest product information available at the time of publication. **Triple S** reserves the right to make changes or improvements to its machines without notice.

FOR YOUR CONVENIENCE, RECORD THE FOLLOWING IMPORTANT INFORMATION:

MODEL _____

SERIAL NUMBER _____

PART NUMBER _____

DATE PURCHASED _____

IMPORTANT SAFETY INSTRUCTIONS

READ AND UNDERSTAND ALL WARNINGS AND INSTRUCTIONS BEFORE USING THIS APPLIANCE!

WARNING! To reduce the risk of fire, electric shock, or injury:

1. Unplug from outlet when not in use and before servicing.
2. Do not use outdoors. Protect the machine from rain.
3. Do not allow to be used as a toy. Close attention is necessary when used by or near children.
4. Use only as described in this manual.
5. Never use this machine to pick up volatile or explosive materials!
6. Do not use this machine for pick up of dust or dry debris.
7. Do not use with damaged cord or plug. If appliance should not work as it should, has been dropped or damaged, left outdoors, or dropped into water, return it to service center.
8. Do not pull or carry by cord, use cord as handle, close a door on cord or pull cord around sharp edges or corners. Do not run appliance over cord. Keep cord away from heated surfaces.
9. Do not unplug by pulling on cord. To unplug, grasp the plug, not the cord
10. Do not handle plug or appliance with wet hands. Do not immerse. Keep the machine in a dry building.
11. Do not put any objects into opening. Do not use with any opening blocked: keep free of dust, lint, hair and anything that may reduce airflow.
12. Keep hair, loose clothing, fingers and all parts of the body away from openings and moving parts.
13. Turn off all controls before unplugging.
14. Do not use in areas where flammable or combustible liquids such as gasoline may be present.
15. Connect to a properly grounded outlet only.
16. Do not use water that is hotter than 82°C (180°F).
17. To prevent damage to the solution system, do not store in freezing temperatures without proper maintenance.

Grounding Instructions

This machine must be grounded. If it should malfunction or break down, grounding provides a path of least resistance for electric current to reduce the risk of electric shock. This machine is equipped with a cord having an equipment-grounding conductor and grounding plug. The plug must be inserted into an appropriate outlet that is properly installed and grounded in accordance with all local codes and ordinances.

WARNING - Improper connection of the equipment-grounding conductor can result in a risk of electric shock. Check with a qualified electrician or service person if you are in doubt as to whether the outlet is properly grounded. Do not modify the plug provided with the machine - if it will not fit the outlet, have a proper outlet installed by a qualified electrician.

This machine is for use on a nominal 120-volt circuit, and has a grounded plug that looks like the plug illustrated in figure A. A temporary adapter that looks like the adapter illustrated in figures B and C may be used to connect this plug to a 2-pole receptacle as shown in figure B if a properly grounded outlet is not available. The temporary adapter should be used only until a properly grounded outlet (figure A) can be installed by a qualified electrician. The green colored rigid ear, lug, or the like extending from the adapter must be connected to a permanent ground such as a properly grounded outlet box cover. Whenever the adapter is used, it must be held in place by a metal screw.

NOTE: In Canada, the use of a temporary adapter is not permitted by the Canadian Electrical Code

EXTENSION CORDS

Use only three-wire 14/3 or larger gauge approved extension cords that have three-prong grounding type plugs and three-pole receptacles that accept the appliance's plug. Replace or repair any damaged cords or plugs.

When servicing, refer to authorized person only. Use only identical replacement parts.

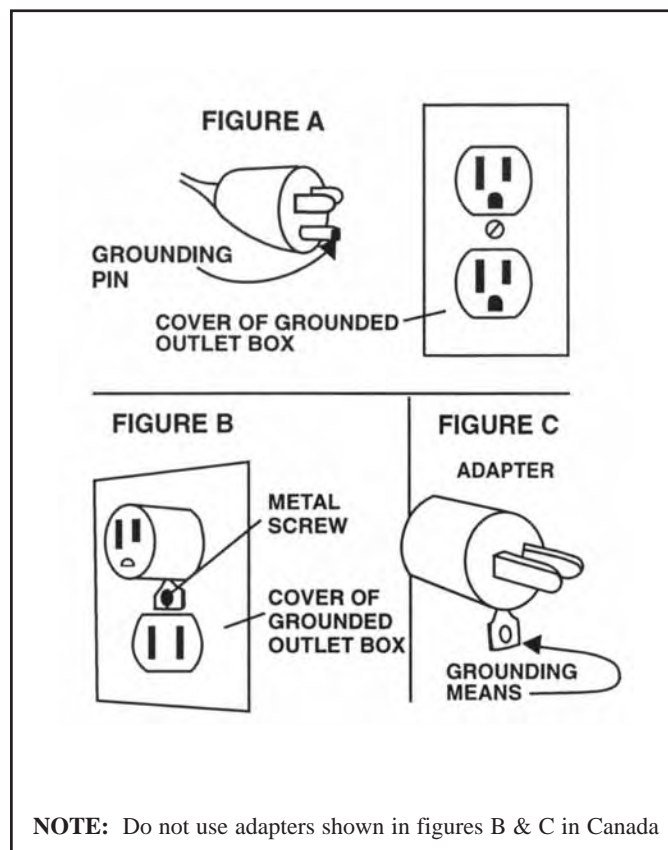

OPERATING INSTRUCTIONS

WARNING! For the safe operation of this machine follow the instructions given in this booklet and the training given by your supervisor. Failure to do so can result in personal injury and/or damage to machine and property!

DO NOT OPERATE MACHINE IN AN EXPLOSIVE ENVIRONMENT!

NEVER USE THIS MACHINE TO PICK UP VOLATILE OR EXPLOSIVE MATERIALS!

The model shown in this manual is intended for commercial use.

DO NOT OPERATE MACHINE IN AN EXPLOSIVE ENVIRONMENT!

ASSEMBLY & OPERATION

1. Connect one end of the vacuum hose to the intake port of the extractor located on the top, rear of the unit (above the dump valve) and the other end to the wand.
2. Connect the one end of the solution hose to the brass water discharge fitting on the lower front of the extractor and the other end to the valve connection on the floor wand.
3. Fill the solution tank (the rectangular opening located on the top of the machine that does not have a cover) with warm or hot water, plus a commercial grade carpet cleaning chemical. Use dilution recommendations located on the chemical bottle. This unit holds 5-gallons of liquid. **NOTE: A low-foaming solution should be used. If not a defoamer must be used to keep the foam to a minimum during use to protect your vacuum motor. Defoamer if used is placed in the recovery tank prior to operating the unit.**
4. Once you have completed all of the above and your unit is plugged into a grounded outlet, turn on the pump switch, which will start to pressurize the unit.
5. Turn on the vacuum switch.
6. Holding the wand with two hands, activate the solution by squeezing the lever on the wand (located at the top of the wand). Spray will start to flow from the jets located at the pick up end of the wand.
7. With one hand squeezing the wand lever, the other hand should be putting downward pressure on the wand and dragging the wand backwards across the carpet towards the operator. This is basically wringing the water out of the carpet and pulling dirt embedded in the carpet up while the suction created by the vacuum motor picks up the water & dirt and empties it into the recovery tank.
8. Repeat step #7 without putting more solution down to extract greater quantities of water from the carpet. Doing this extra times will shorten the drying time required for your carpet.
9. After using all of the solution from the solution tank, you should empty the recovery tank using the dump valve located at the lower rear of the machine by bringing the unit to a janitor's sink, commode, etc. and pulling up on the "T" handle on the top of the valve.
10. Once the recovery tank is emptied, lower the "T" handle and repeat steps 3-9 as needed to clean the remaining carpet.
11. The cover on the recovery tank must always be in place while using the extractor. The suction from the unit during operation holds this in place.
12. During recovery, note that 100% recovery of all liquid will not be achieved.

DAILY OR REGULAR MAINTENANCE

1. Rinse solution and recovery tanks out after every use. Never leave any liquid in the system after use during storage. Store unit in a warm place. If unit is left in a freezing environment with liquid left in the system, the pump and pump housing could crack, requiring replacement of the pump.
2. Twice a month, flush machine with a solution of white vinegar (one quart vinegar to two gallons of water) or anti-browning solution mixed as directed. This will prevent build up of alkaline residue in the machine.
3. If spray jet on the wand becomes clogged, remove spray tip, wash thoroughly and blow dry.

PERIODIC MAINTENANCE

1. Periodically inspect all hoses, electrical cable and connections on the machine. Frayed or cracked hoses should be replaced to eliminate vacuum or water pressure loss. Check power cable for damage. Repair or replace damaged cord to prevent fire or electric shock.

SSS SCEPTER PE50 5-GALLON BOX EXTRACTOR FINAL ASSEMBLY

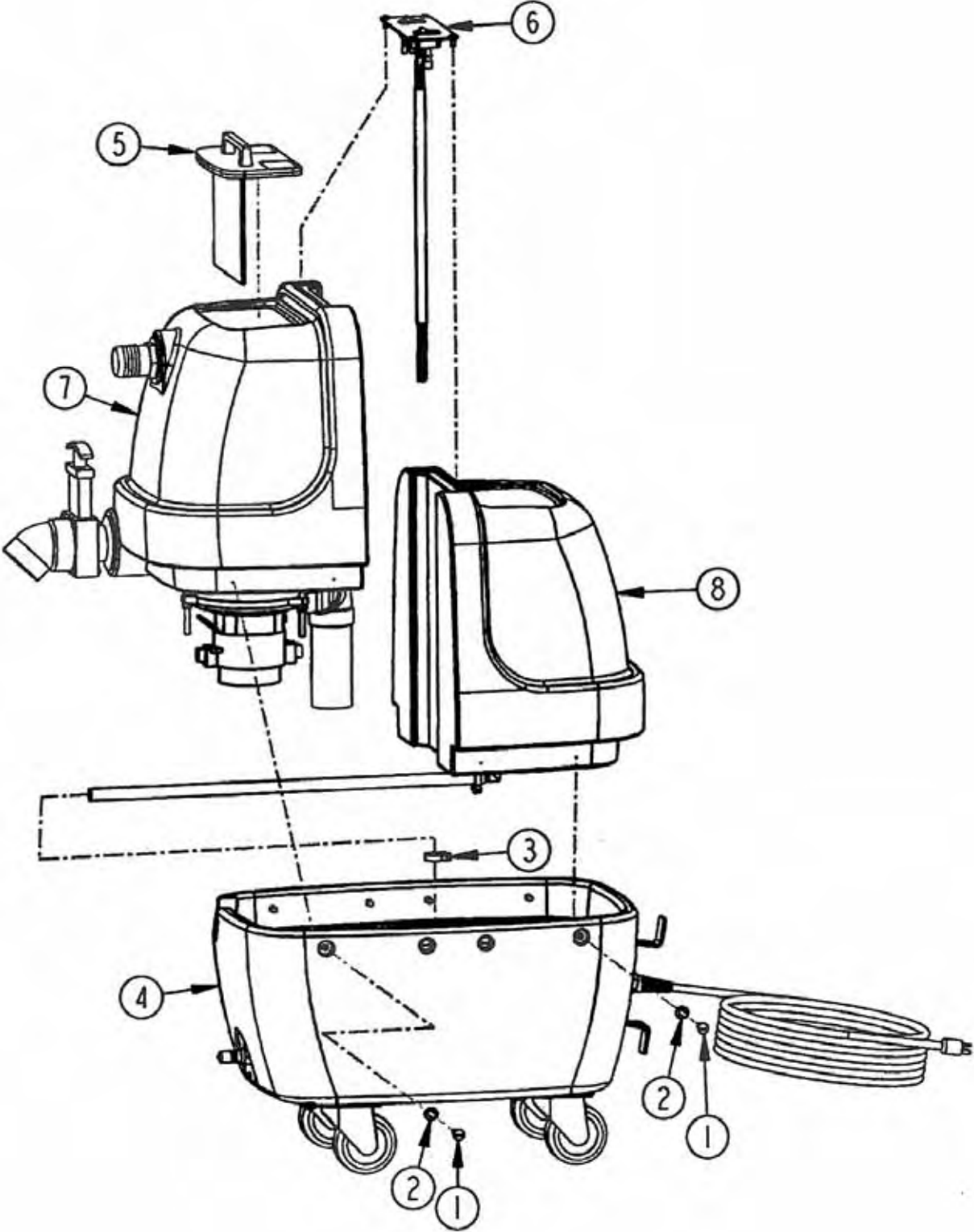

**SSS SCEPTER PE50 5-GALLON BOX EXTRACTOR FINAL
ASSEMBLY PARTS LIST**

ITEM	PART NO.	DESCRIPTION	QTY.
1	962010	Screw-1/4-20 x 1 HTB FT	8
2	W104D	Washer-1/4 Flat SAE SS	8
3	S453P	Clamp-Hose	4
4	251802	Base-Black	1
5	255113	Lid Assembly	1
6	256404	Control Plate Assembly	1
7	258607	Tank-Recovery-Black	1
8	258602	Tank-Solution-Black	1

SSS SCEPTER PE50 5-GALLON BOX EXTRACTOR RECOVERY TANK

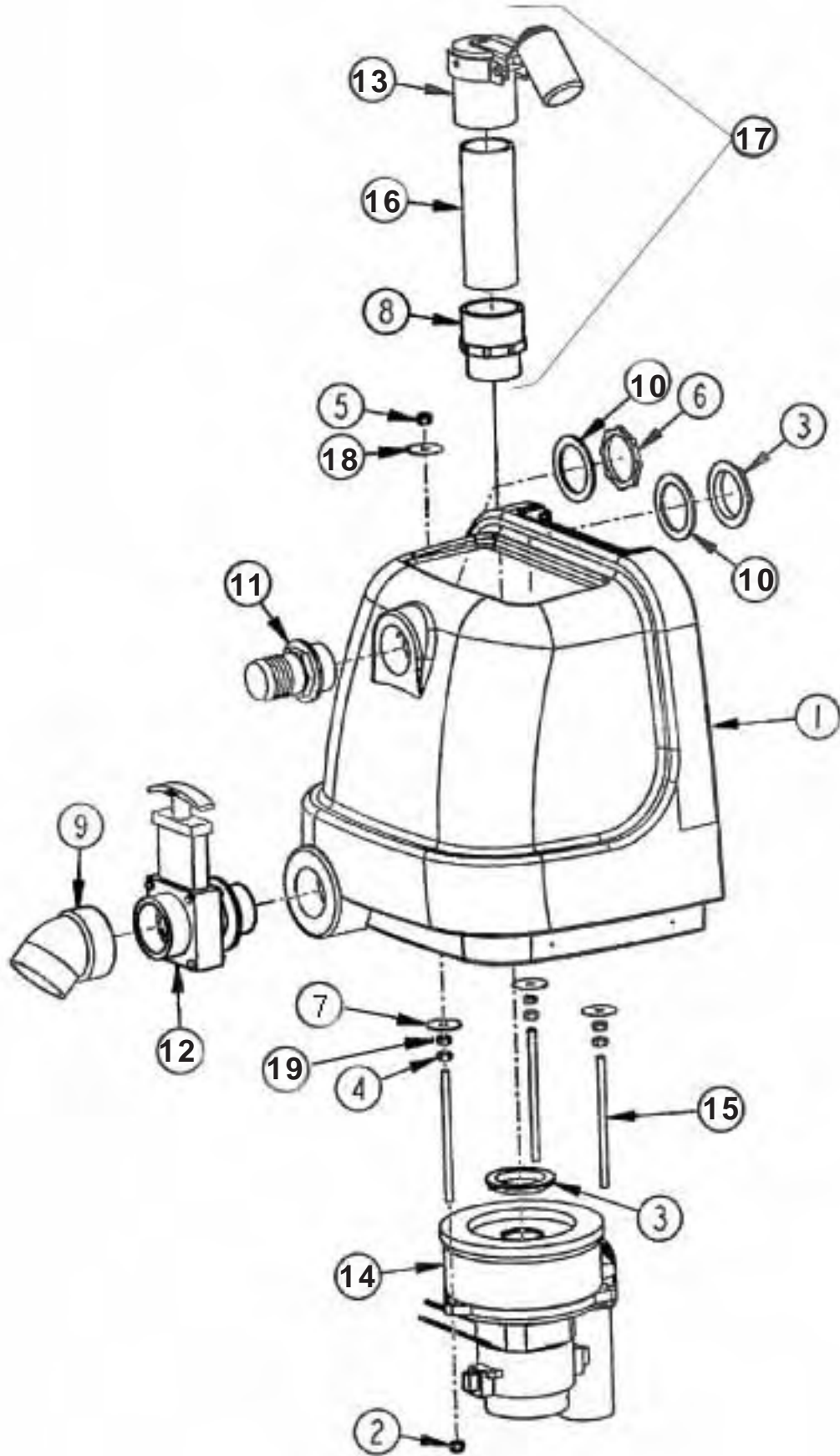

**SSS SCEPTER PE50 5-GALLON BOX EXTRACTOR RECOVERY
TANK PARTS LIST**

ITEM	PART NO.	DESCRIPTION	QTY.
1	258607	Tank-Recovery-Black	1
2	920011	Nut-1/4-20 Elastic Stop	3
3	S400P5	Locknut-1 1/2	3
4	920004	Nut-1/4-20 Hex	6
5	920665	Nut-1/4 SS Hex Nyloc	3
6	920676	Locknut-1 1/2 Serration	1
7	W311D	Washer-1/4 Fender Zinc	3
8	253306	Fitting-Pipe 1 1/2 MPT	1
9	S400PB4	Elbow	1
10	S400P6	O-Ring	2
11	250201	Adaptor-1 1/2" MPT	1
12	S400PB	Drain Valve	1
13	255020	Kit-Shut Off Assembly	1
	253310	Filter-Foam (Not Shown)	1
14	205250	Motor-Vac	1
15	257403	Rod-Threaded SS 6.125"L	3
16	257017	Standpipe	1
17	257018	Standpipe Assembly w/ Shut Off	1
18	W104D	Washer-1/4 Flat SAE SS	3
19	980002	Washer-1/4 Split Lock	3

SSS SCEPTER PE50 5-GALLON BOX EXTRACTOR SOLUTION TANK

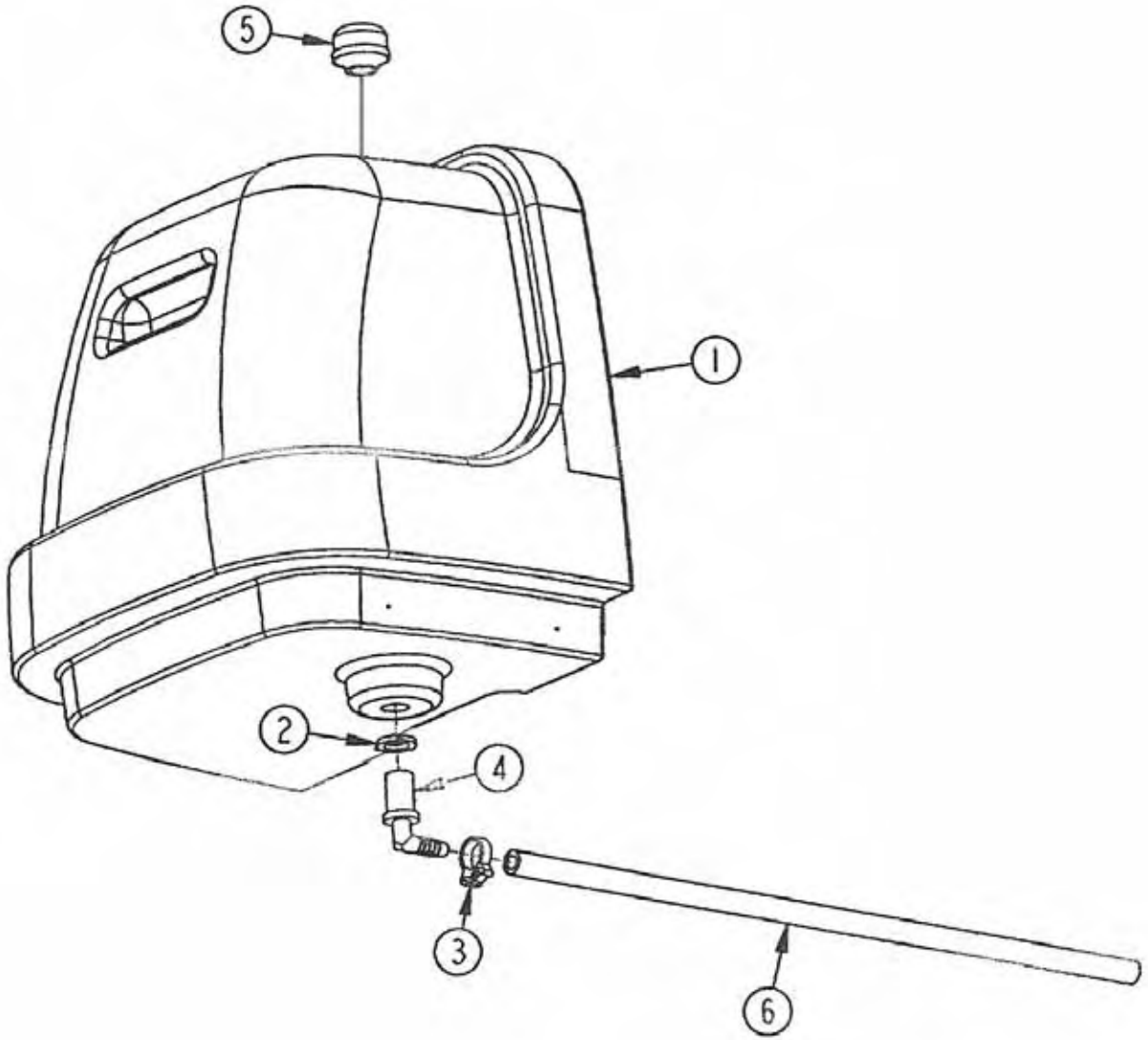

**SSS SCEPTER PE50 5-GALLON BOX EXTRACTOR SOLUTION TANK
PARTS LIST**

ITEM	PART NO.	DESCRIPTION	QTY.
1	258602	Tank-Solution-Black	1
2	S372P	Washer-1.5 OD x 0.6875 Nylon	1
3	202050	Clamp-Solution Hose	1
4	211310	Body-90 Jet w/Locknut	1
5	S626P	Strainer-3/8 NPT	1
6	214111	Hose-3/8 x 18"	1

SSS SCEPTER PE50 5-GALLON BOX EXTRACTOR BASE ASSEMBLY

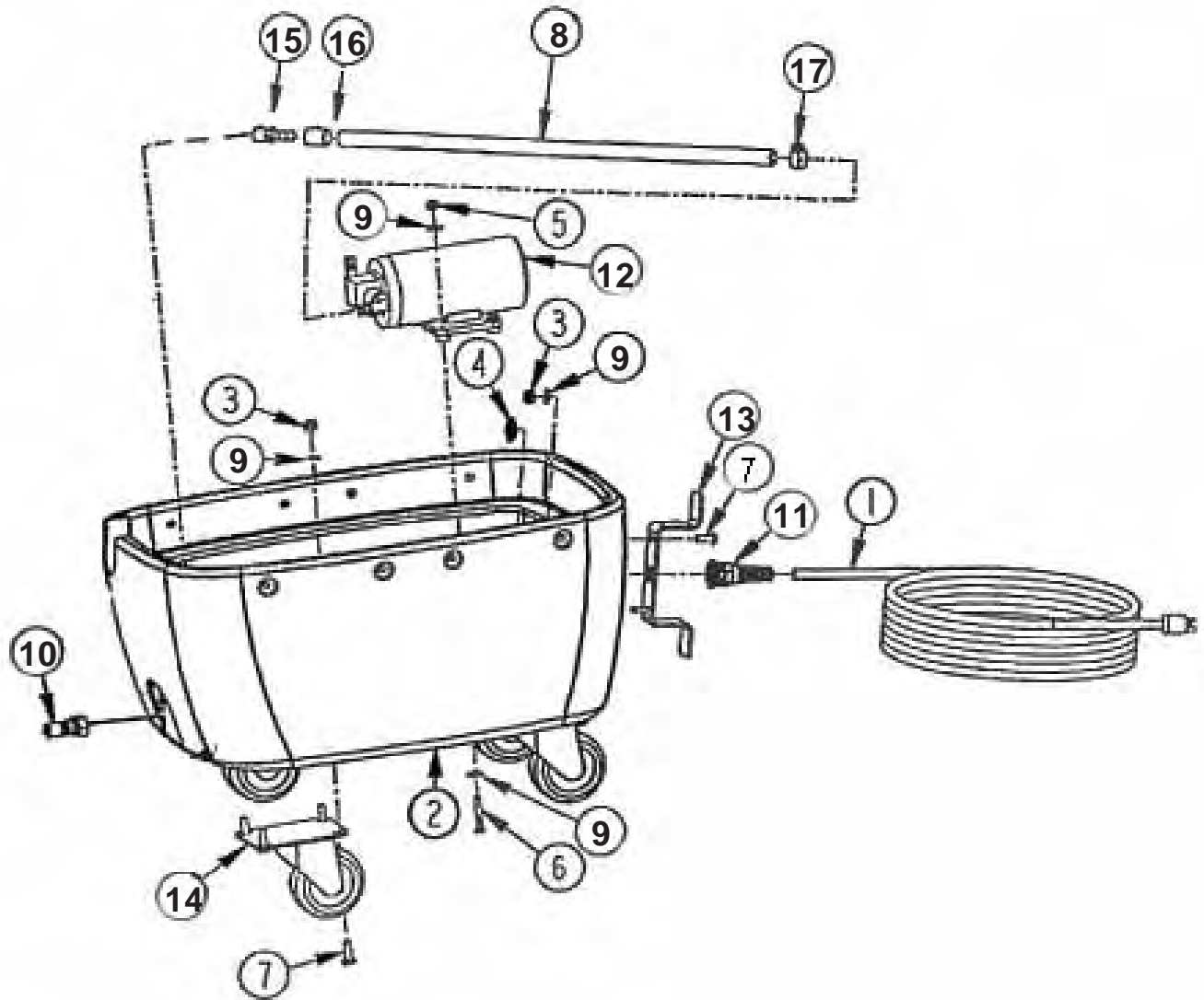

**SSS SCEPTER PE50 5-GALLON BOX EXTRACTOR BASE ASSEMBLY
PARTS LIST**

ITEM	PART NO.	DESCRIPTION	QTY.
1	908059	Cord Asm-25' 16-SJT	1
2	251802	Base-Black	1
3	920011	Nut-1/4-20 Elastic Stop	18
4	920680	Locknut-3/8 Zinc	1
5	920666	Nut-10-32 Hex SS Nyloc	2
6	962113	Screw-10-24 x 1.25 SS PHP	2
7	962010	Screw-1/4-20 x 1 HTB FT	18
8	S250P	Hose-Solution 3/8	1
9	W104D	Washer-1/4 Flat SAE SS	16
10	203302	Quick Connect-1/4 Male	1
11	A13020	Strain Relief	1
12	257002	Pump-60 PSI	1
13	250807	Bracket-Cord	1
14	259701	Caster-Swivel 3 x 1-1/4	4
15	203359	Fitting-Hose Barb 3/8	1
16	202050	Clamp-Solution Hose	1
17	S453P	Clamp-Hose	1

SSS SCEPTER 5-GALLON BOX EXTRACTOR CONTROL PLATE ASSEMBLY

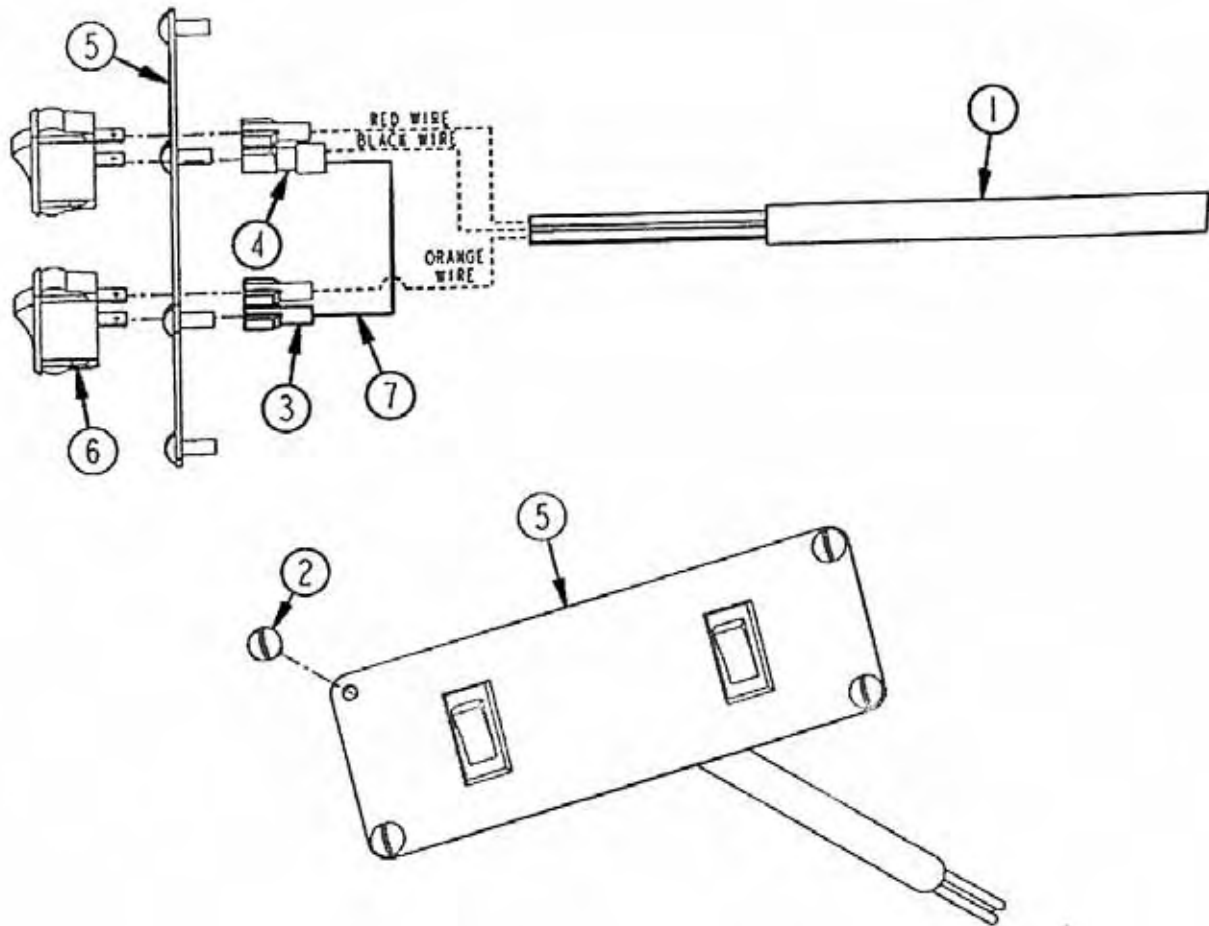

**SSS SCEPTER PE50 5-GALLON BOX EXTRACTOR CONTROL
PLATE ASSEMBLY PARTS LIST**

ITEM	PART NO.	DESCRIPTION	QTY.
1	908115	Cord-Control 16/5-54"	1
2	962015	Screw-10-32 x 3/8 PHP	4
3	S948P	Terminal-Female	3
4	911543	Terminal-Yellow Fem DICS	1
5	256401	Switch Plate	1
6	911089	Switch-Rocker 20 Amp	2
7	251344	Wire-14 Gauge 6"	1
	256404	Complete Control Plate Assm.	1

SSS SCEPTER PE50 5-GALLON BOX EXTRACTOR PUMP ASSEMBLY

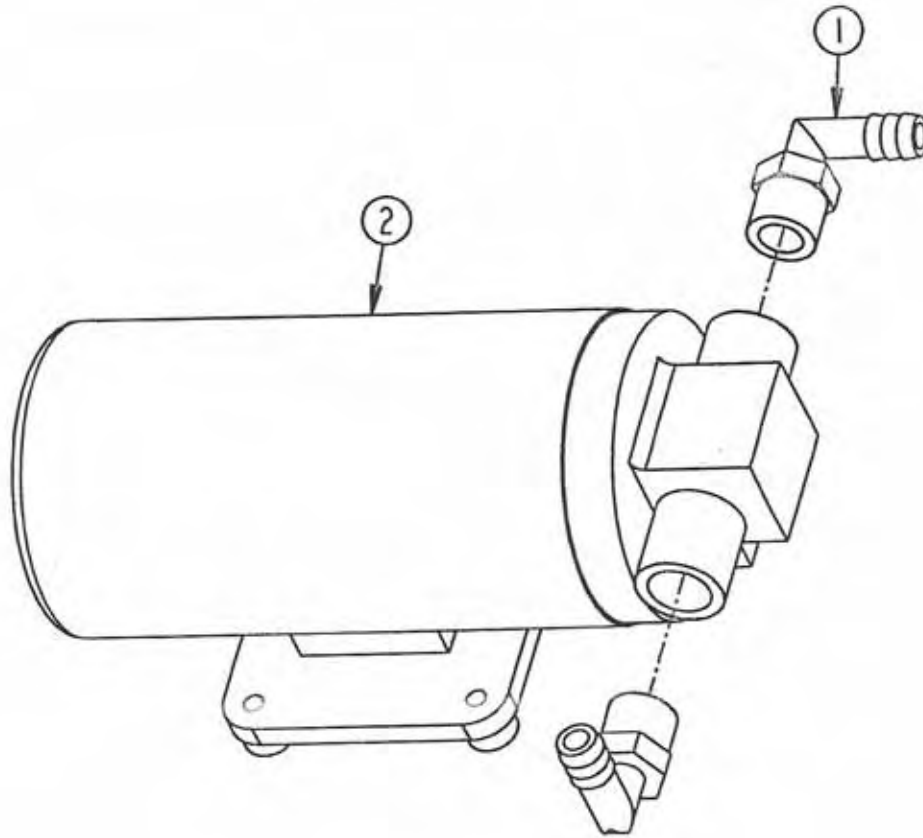

SSS SCEPTER PE50 5-GALLON BOX EXTRACTOR PUMP ASSEMBLY PARTS LIST

ITEM	PART NO.	DESCRIPTION	QTY.
1	3765	Elbow-Male 3/8 to 3/8	2
2	257002	Pump-60 PSI	1

SSS SCEPTER PE50 5-GALLON BOX EXTRACTOR VACUUM MOTOR ASSEMBLY

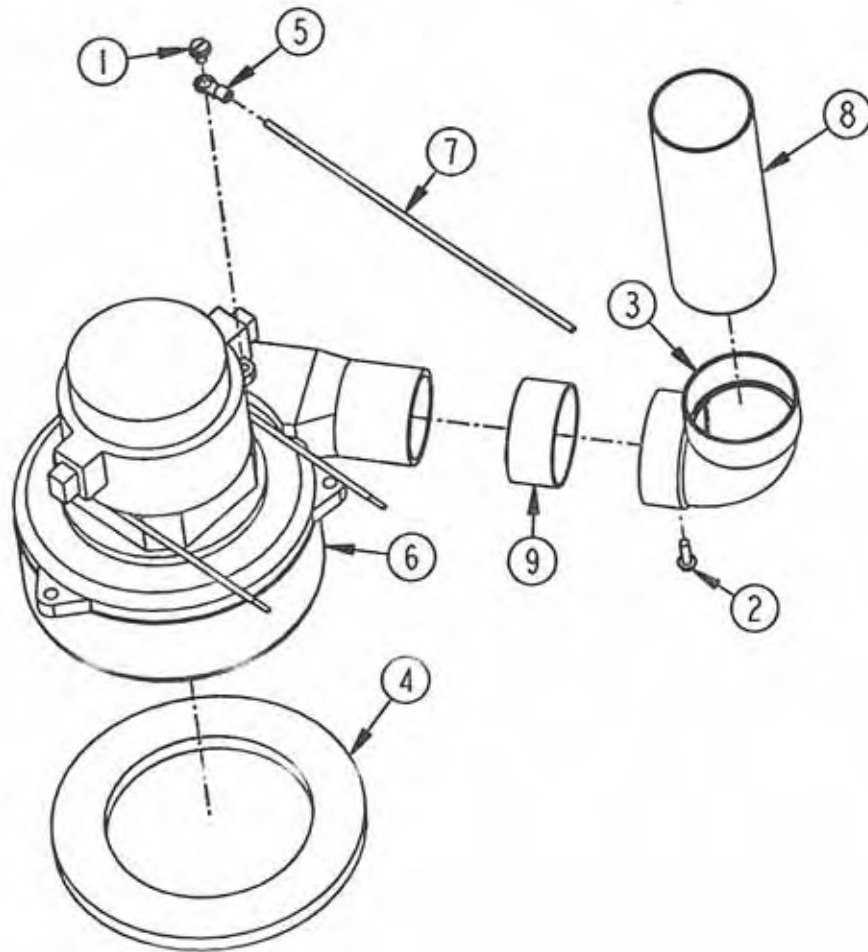

SSS SCEPTER PE50 5-GALLON BOX EXTRACTOR VACUUM MOTOR ASSEMBLY PARTS LIST

ITEM	PART NO.	DESCRIPTION	QTY.
1	962211	Screw-10 x 3/8 Hex Washer	1
2	962119	Screw-8 x 1/2 HH Tek-Zinc	1
3	252812	Elbow-Short 90D PVC	1
4	603473	Gasket-Top Vac	1
5	911553	Terminal-Ring Blue 16-14	1
6	205250	Motor-Vacuum	1
7	911604	Lead Asm w/Ring Terminal	2
8	257010	Pipe-PVC 2" OD x 5"L	1
9	257004	Pipe-PVC 2" OD x 0.75"L	1

SSS SCEPTER PE50 5-GALLON BOX EXTRACTOR HOSE ASSEMBLY

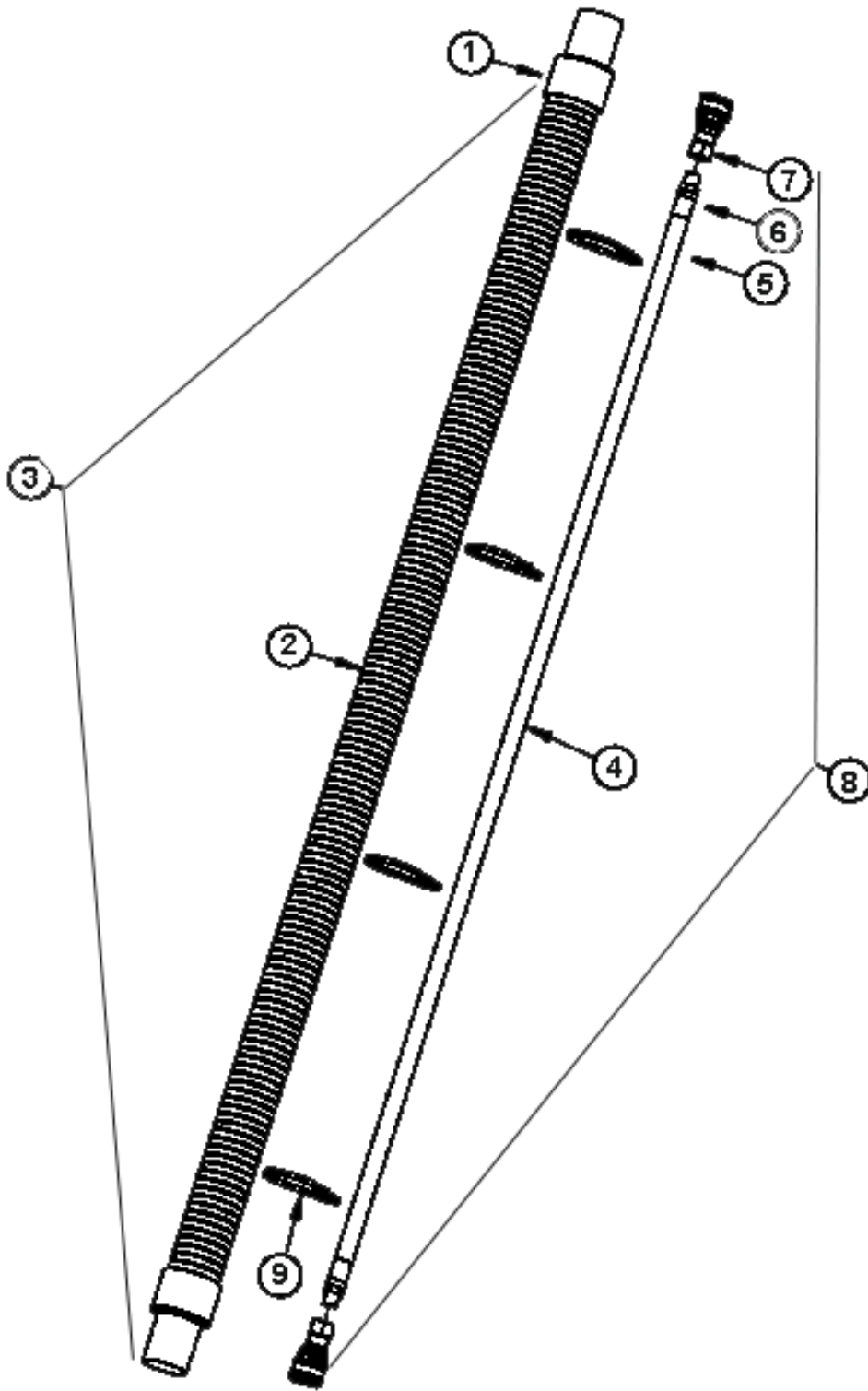

**SSS SCEPTER PE50 5-GALLON BOX EXTRACTOR HOSE
ASSEMBLY PARTS LIST**

ITEM	PART NO.	DESCRIPTION	QTY.
1	252403	Cuff-Hose 1.5 x 1.5"	2
2	254105	Hose-Vacuum 1.5" (Per Foot, No Cuffs)	12 ft
3	254138	Hose-Vacuum Assm 12' w/Cuffs	1
4	S250P	Hose-Solution 3/8" (Per Foot)	12 ft
5	203359	Fitting-Hose Barb 3/8"	2
6	202050	Clamp-Solution Hose	2
7	203308	Quick Connect - 1/4" Female	2
8	254139	Hose-Solution Assm 12' w/QC	1
9	911104	Tie-Cable	4

SSS SCEPTER PE50 5-GALLON BOX EXTRACTOR WAND ASSEMBLY

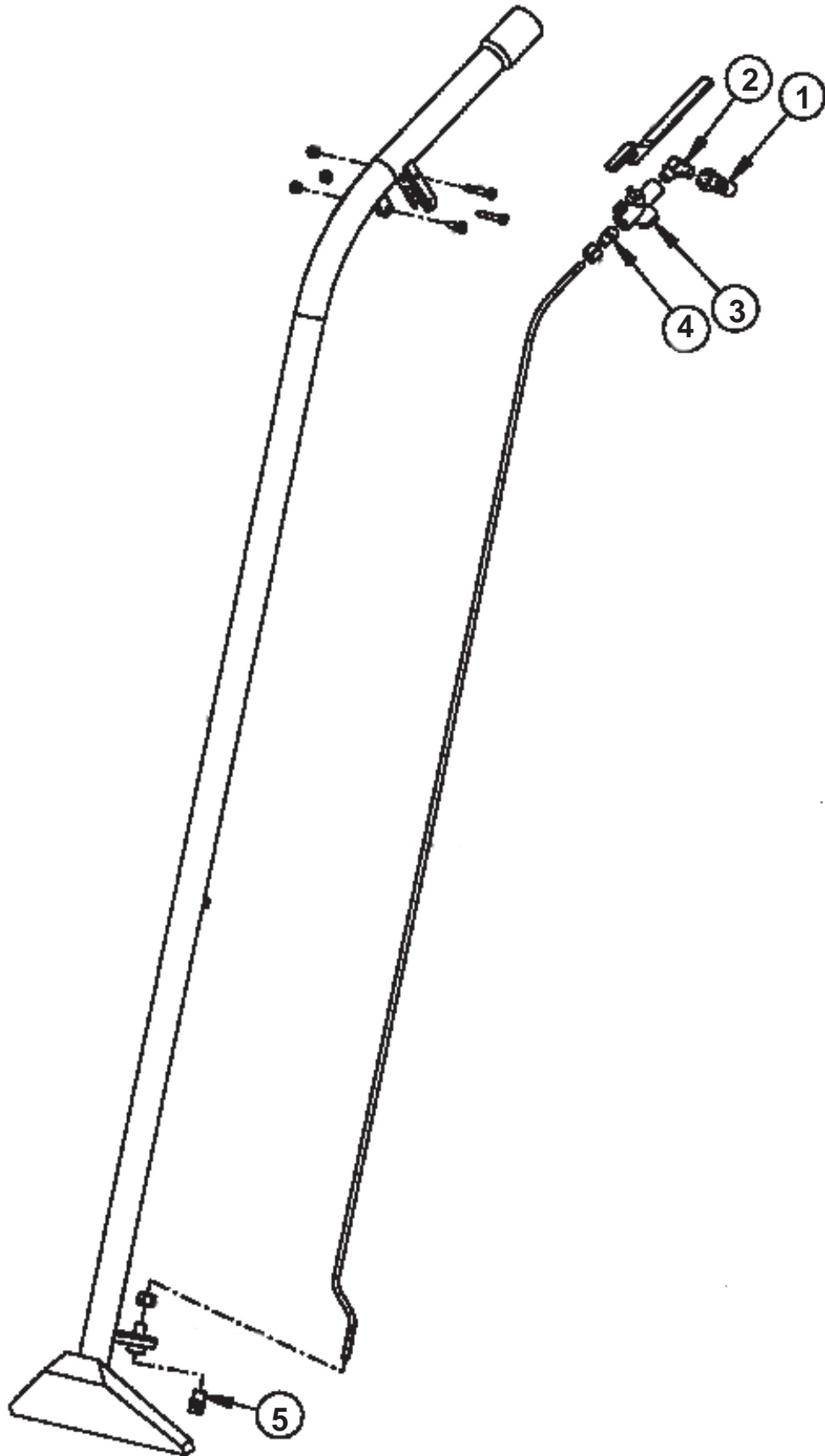

**SSS SCEPTER PE50 5-GALLON BOX EXTRACTOR WAND
ASSEMBLY PARTS LIST**

ITEM	PART NO.	DESCRIPTION	QTY.
1	203302	Quick Disconnect-Male 1/4	1
2	252809	Elbow-1/4 to 1/4	1
3	259402	Valve-120 PSI Plastic Black	1
4	255703	Nipple-1/4 Male Threaded	1
5	254903	Spray Jet 1/8" Brass	1
	259801	1-Jet Wand Assembly-Complete	1

WARRANTY POLICY SSS SCEPTER PE50 5-GALLON BOX EXTRACTOR

The **Triple S** Scepter PE50 5-Gallon Box Extractor has been manufactured, tested and inspected in accordance with specific engineering requirements and is **WARRANTED** to be free from defects in workmanship and materials as follows:

Five (5) years parts, One (1) year labor – Rotational molded tanks.
One (1) year parts & labor – All other components unless excluded below.

This warranty extends to the original user/purchaser and only when used, operated and maintained in accordance with **Triple S'** Operating and Maintenance instructions.

This warranty does not apply to certain wear parts of the machine such as electrical cords, carbon motor brushes, hoses, tools, etc., nor does it apply to damage or failure caused by improper use, abuse or neglect. Warranty credit or replacement of return parts including motors, tools, etc., is subject to incoming inspection of those items.

To secure repair under this warranty, the following procedure should be taken:

- The inoperative machine or warranted parts must be delivered to the authorized dealer with shipping and delivery charges prepaid. If unable to locate the Dealer, you may contact **Triple S** at the address listed herein for the location of the nearest **Triple S** repair center or agent or for other instructions pertaining to your warranty difficulty.
- Upon compliance with the above warranty procedure, all warranted repairs would be completed at no additional charge or cost to the user.
- Only **Triple S** or its authorized dealers and agents may make no charge warranty repairs on this product. All others do so at their own risk.

This warranty limits **Triple S** liability to the repair of the product and/or warranted parts replacement and does not include incidental or consequential damages arising from the use of a **Triple S** machine whether defective or not.

This warranty is in lieu of all other expressed or implied warranties and is extended to the original purchaser/user.



2 Executive Park Drive • Billerica, MA 01862
Ph: (800) 323-2251 • Fax (978) 667-9360
www.triple-s.com