

Sanitary Waste System



- Hands Free Operation
- Reduces Plumbing Problems and Cost
- Odor Control
- Clean and Hygienic



A Better Sanitary Waste System

The Need

Everyday millions of women produce sanitary waste that needs to be disposed of safely, responsibly and with minimum harm to the environment. The Merlin Sanitary Waste System is designed to meet the needs of female patrons and provide a hygienic solution for sanitary waste disposal.

Performance

Compact 3 and 5 gallon bins keep sanitary waste out of site and out of the toilet, reducing blockage that increase the needs for high-cost maintenance. Hands-free foot pedal operation reduces cross-contamination.

Hygienic Design

Contoured bin is easy to clean and does not harbor dirt or germs. The SaniBin System Deodorant controls odors and deactivates harmful bacteria and pathogens. Custom fill liners keep system dry so the interior is never soiled.



Sanitary Waste System Keeps Washrooms Safe and Sanitary

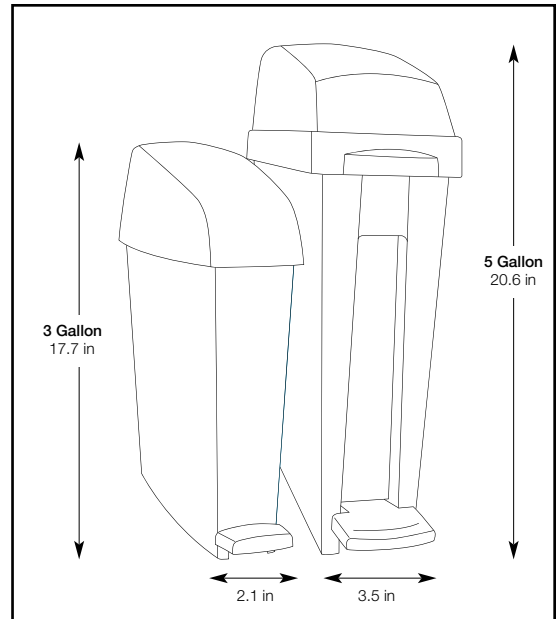

Chute

- Chute length and design ensures even dispersion of waste and does not encroach on waste storage capacity.
- Fluted chute ensures immediate waste drop into bin and is easy to clean.
- Reduced chute length minimizes the risk of undesirable objects being deposited in the bin.

Lid

- Sloping lid prevents objects being placed on top of the bin, and minimizes cross-contamination.
- Secure-fitting lid, that is easy to remove for servicing.

Body

- Smooth body, lid and pedal surfaces that are easy to clean and keep hygienic.
- Made from quality material that retains its appearance and color.

Pedal

- Pedal mechanism engineered for strength and reliability.
- Hands-free pedal operation reduces direct contact with contaminated surfaces.
- Ridge-free pedal design does not collect dust and dirt.

SaniBin System Deodorant

- Unique bottle design dispenses 1 dose (20 gm) when inverted.
- Deodorizing granules activate when waste is placed in bin - effective up to 8 weeks.
- Keeps bin smelling fresh.



Bins

74721
74722

Item

74724
74723
74727

SaniBin 5 Gallon - White
SaniBin 3 Gallon - White

Description

SaniBin System Deodorant
35 oz/1000 gm - 12 per case
SaniBin 5 Gallon Liners
(15 per roll/25 rolls per case)
SaniBin 3 Gallon Liners
(15 per roll/25 rolls per case)

Distributed by: